

ONE-TOUCH SLIDING LOCKS

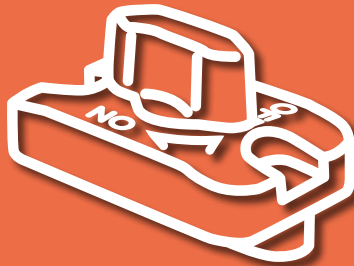

ONE-TOUCH SLIDING LOCKS

ONE-TOUCH INDEXING CLAMPS

LINEAR-MOTION STOPPERS

PNEUMATIC SHAFT-LOCKING CLAMPS

ONE-TOUCH SPINDLE LOCKS

QUICK SHAFT-LOCKING CLAMPS

ONE-TOUCH SLIDING LOCKS

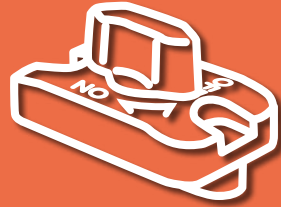

ONE-TOUCH SLIDING LOCKS

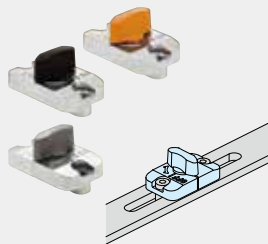

SLIDING LOCKS FOR
SLOTTED HOLE

Part No. QCSL



RISER PLATES FOR
SLIDING LOCK

Part No. QCSLSP

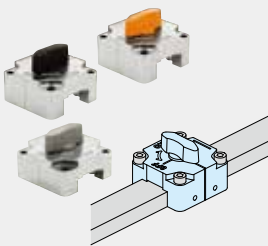

SLIDING LOCKS FOR
SQUARE BAR

Part No. QCSQ

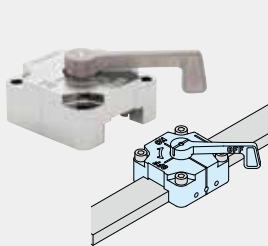

SLIDING LOCKS FOR
SQUARE BAR WITH HANDLE

Part No. QCSQ-L

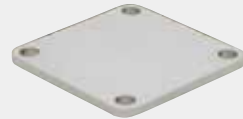

RISER PLATES FOR
SLIDING LOCK

Part No. QCSQSP

ONE- TOUCH INDEXING CLAMPS

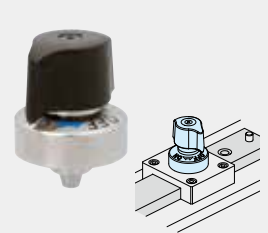

ONE-TOUCH INDEXING
CLAMPS

Part No. QCIC-F

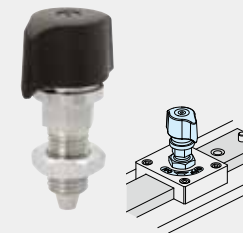

ONE-TOUCH INDEXING
CLAMPS

Part No. QCIC-M

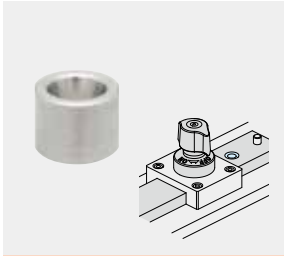

TAPERED BUSHINGS

Part No. QCIC-TB

LINEAR-MOTION STOPPERS

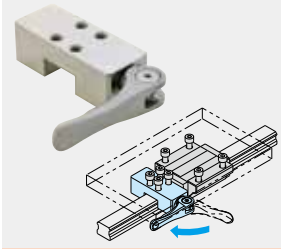

LINEAR-MOTION STOPPERS

Part No. LSM

PNEUMATIC SHAFT-LOCKING CLAMPS

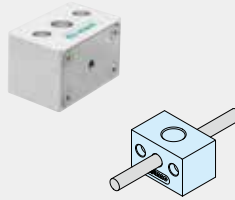

PNEUMATIC SHAFT-LOCKING CLAMPS

Part No. PSLC-L

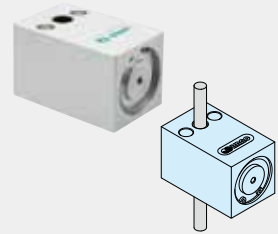

PNEUMATIC SHAFT-LOCKING CLAMPS

Part No. PSLC-M

ONE-TOUCH SPINDLE LOCKS

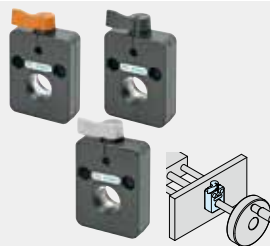

ONE-TOUCH SPINDLE LOCKS

Part No. QCSPL

QUICK SHAFT-LOCKING CLAMPS

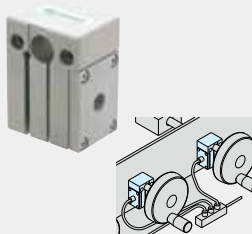

QUICK SHAFT-LOCKING CLAMPS (Pneumatic)

Part No. QSCA

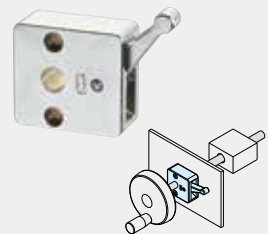

QUICK SHAFT-LOCKING CLAMPS

Part No. QSC

ONE-TOUCH SLIDING LOCKS

New solution for
sliding adjustment!

ONE-TOUCH SLIDING LOCKS



One-touch Sliding Lock is a fixing
component that enables easy &
secure locking in sliding adjustment.

This dramatically improves reliability and
safety in set-ups of various devices.

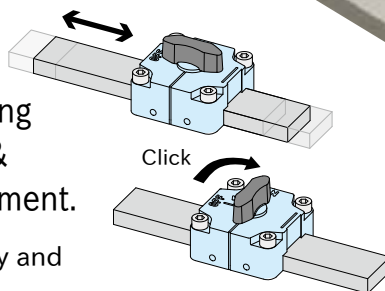

Conventional Method

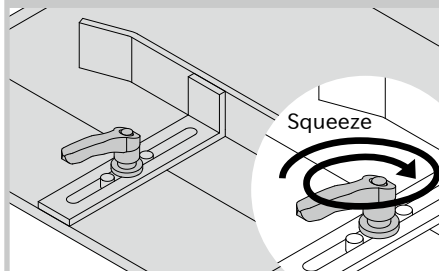

Required to tighten by main force to
prevent misalignment.

IMAO Method

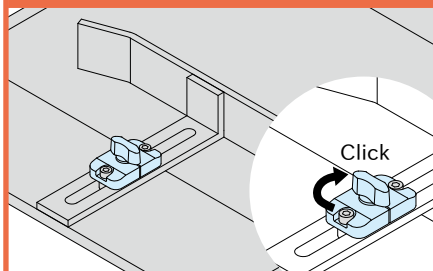

Prevents misalignment with
easy operation!

Feature

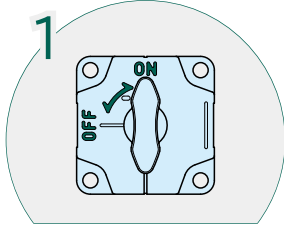

High Visibility

Easy-to-read ON/OFF position

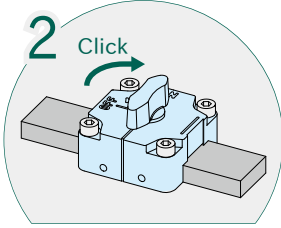

Leveling of Operation

The knob clicks when it is locked/unlocked.

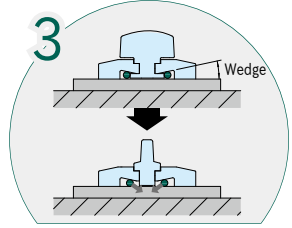

Secure Locking

Secure locking with wedge structure.

Lineup

Sliding Locks for Slotted Hole

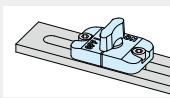

Plastic knob is available in black or orange. Metal knob is resistant to damage.

Sliding Locks for Square Bar

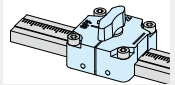

Can be used with commercially-available square bars



Knob is available in plastic or metal.

Handle is accessible from the side even in tight space.

Application

For Adjusting Camera Position

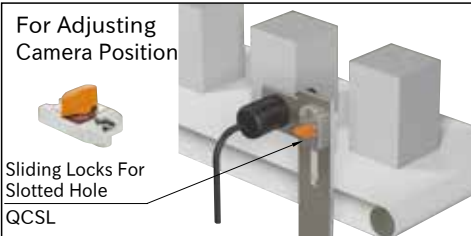

Sliding Locks For Slotted Hole QCSL

For Adjusting Stamp Base Position



Sliding Locks For Square Bar QCSQ

For Adjusting Workpiece Guide



Sliding Locks For Slotted Hole QCSL

QCSL

SLIDING LOCKS FOR SLOTTED HOLE



Type	Body	Knob	Shafts / Wedge	Ball Plunger
QCSL-OG	Die-cast zinc Chrome plated	Polyamide (glass-fiber reinforced)	Stainless steel	Polyacetal
QCSL-BK				
QCSL-S		SCS13 stainless steel (Equivalent to SUS304)		

**QCSL-OG**

(Plastic Knob, Orange)

**QCSL-BK**

(Plastic Knob, Black)

**QCSL-S**

(Metal Knob)

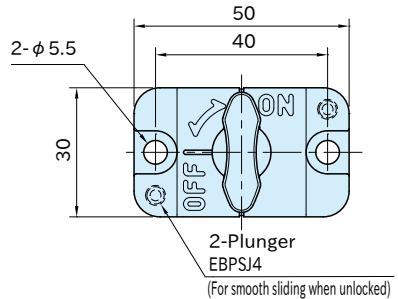
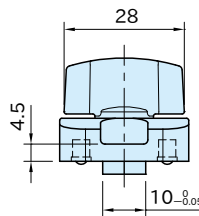

(For smooth sliding when unlocked)

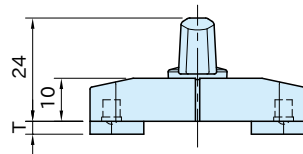

■ Locking Mechanism

The shafts are locked being pushed into the wedged spaces when sliding load is applied in horizontal direction.

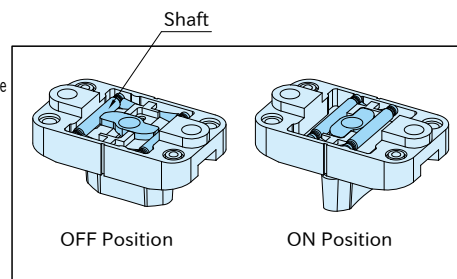
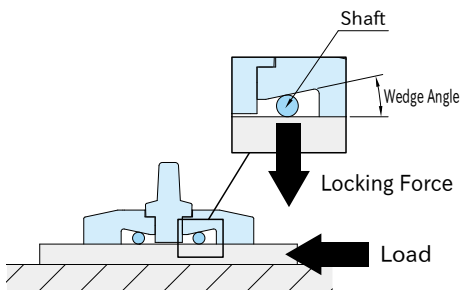

QCSL-OG (Plastic Knob, Orange)		QCSL-BK (Plastic Knob, Black)		QCSL-S (Metal Knob)		T
Part Number	Weight (g)	Part Number	Weight (g)	Part Number	Weight (g)	
QCSL1003-OG	80	QCSL1003-BK	80	QCSL1003-S	95	3
QCSL1006-OG	80	QCSL1006-BK	80	QCSL1006-S	95	6

How To Use

Operating Instructions

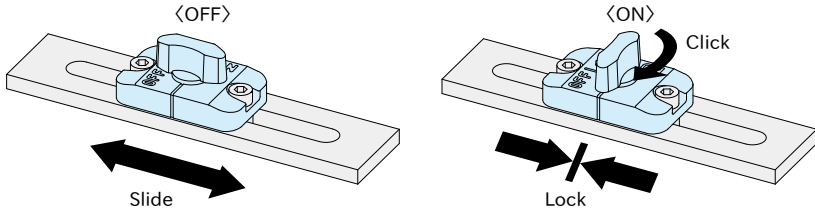

The slide is locked when the knob is at “ON” position.

Usage Instructions * Refer to the “Note” for safety use.

1. Slide the steel bar.

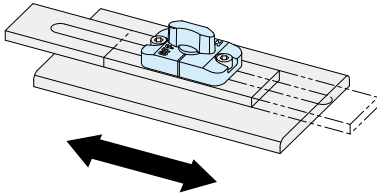

2. Attach/remove the steel bar.

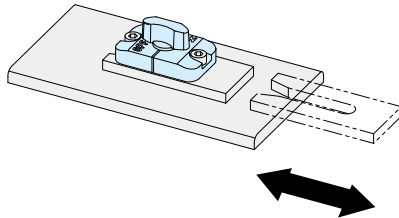

3. Slide the Sliding Locks For Slotted Hole.

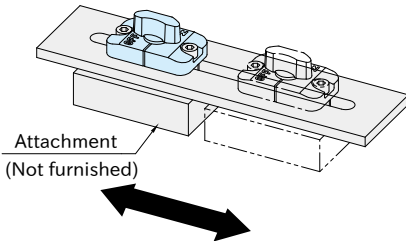

4. Attach/remove the Sliding Locks For Slotted Hole.

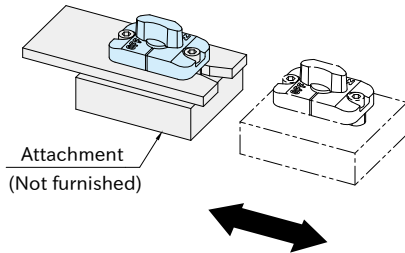

Steel Bar Materials

- Usable Materials: Flat bar (JIS h14 grade) made of SS400, S45C or SUS304 etc.
- Machining of slotted hole: Recommended tolerance of the slotted hole to prevent chattering is shown as below.
For more accurate sliding, machine the slotted hole to fit the dimension of 10mm(-0.05 to 0) on the bottom of Sliding Locks. Remove the burr around the slotted hole to ensure secure locking.

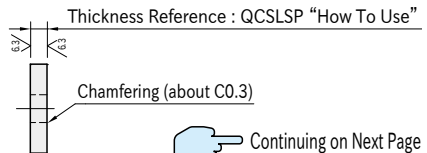
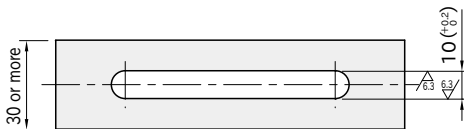

Performance Curve

■ The displacement of steel bar by axial load (Static load from single direction)

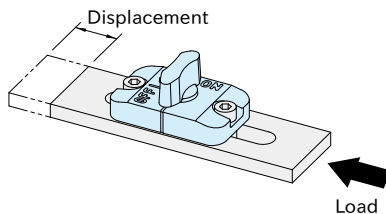
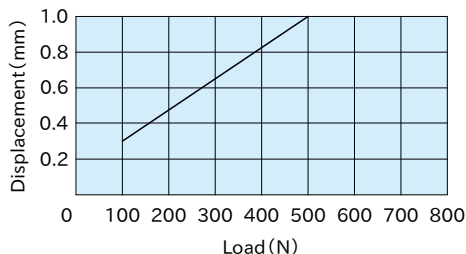

Note: The above data is for a flat bar made of SUS304 stainless steel, SS400 steel and S45C steel.
Using an aluminum flat bar, the surface will be scratched or dent by applied load.

Technical Information

- Heat resistance : Up to 90°C
- Rated load : Up to 500N

Note

The following conditions may cause displacement increasing or misalignment.

1. Use under slippage or chattering caused by vertical or horizontal loads

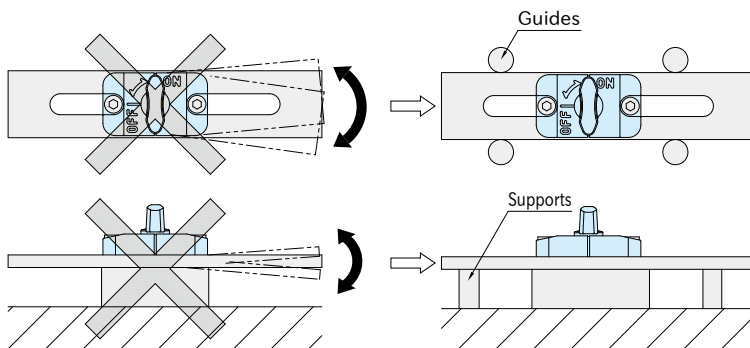

2. Use with a clearance between the steel bar and the base when the Sliding Locks at "ON" position.

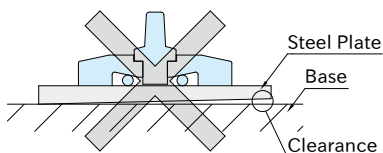

3. Use under excess shock or vibration

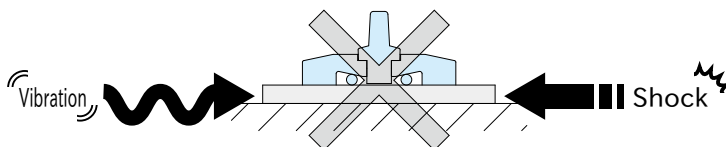

QCSLSP

RISER PLATES FOR SLIDING LOCK



Body
SUS304 stainless steel

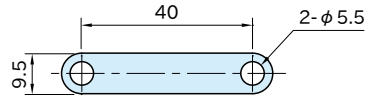

Part Number	T ₁	Weight (g)
QCSLSP1002	2	6
QCSLSP1003	3	10

How To Use

How to Use Riser Plate

Can be used for various steel thicknesses by attaching the Riser Plates (to be ordered separately).

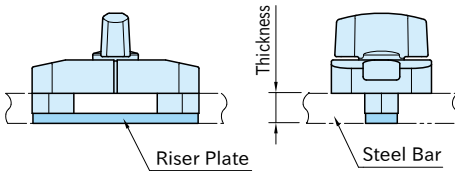

Type	Part No. of Riser Plates	Thickness of Steel Bar(h14) (mm)
QCSL	1003	—
	QCSLSP1002	3 ⁽⁺⁰⁾ _(-0.25)
	QCSLSP1002	5 ⁽⁺⁰⁾ _(-0.3)
	1006	—
QCSLSP1002	6 ⁽⁺⁰⁾ _(-0.3)	
QCSLSP1002	8 ⁽⁺⁰⁾ _(-0.36)	
QCSLSP1003	9 ⁽⁺⁰⁾ _(-0.36)	

How to Use Scale Plate

- You can read the scale with the line on the body of Sliding Lock.
- **ESTN** Scale Plate is separately available.

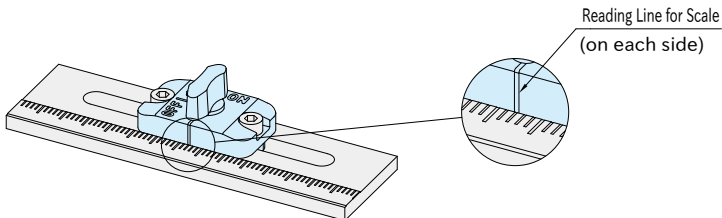

QCSQ

SLIDING LOCKS FOR SQUARE BAR



IMAO

Type	Body	Knob	Shafts / Wedge	Flat Spring
QCSQ-OG	Die-cast zinc Chrome plated	Polyamide (glass-fiber reinforced)	Stainless steel	C519P phosphor bronze
QCSQ-BK				
QCSQ-S		SCS13 stainless steel (Equivalent to SUS304)		

**QCSQ-OG**

(Plastic Knob, Orange)

**QCSQ-BK**

(Plastic Knob, Black)

**QCSQ-S**

(Metal Knob)

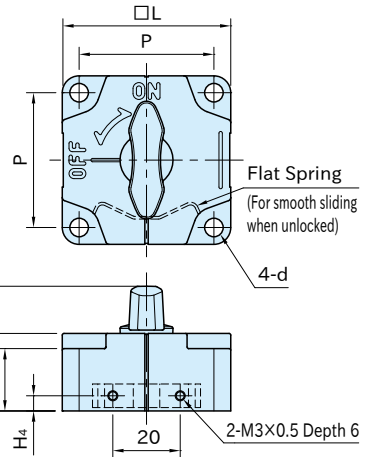
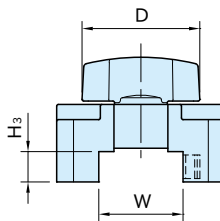

■ Locking Mechanism

The shafts are locked being pushed into the wedged spaces when sliding load is applied in horizontal direction.

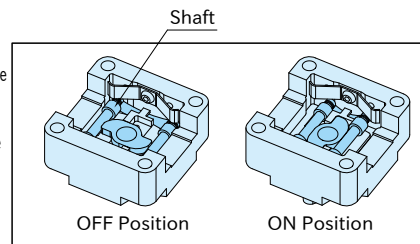
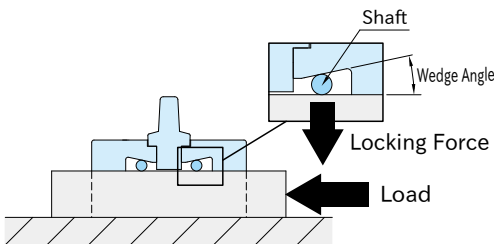

Size	L	H	W ($+0.05$ 0)	H ₃	D	H ₁	H ₂	H ₄	P	d			
QCSQ-OG	40	1212	36	12	28	22	18.5	6	32	4.5			
		1616	40	16		26	22.5	8					
		2509	37	25		23	18.5	4.5					
QCSQ-BK	50	3212	40	32	35	26	21.5	6	40	5.5			
											2512	9	4.5
											3216	12	16

QCSQ-OG (Plastic Knob, Orange)		QCSQ-BK (Plastic Knob, Black)		QCSQ-S (Metal Knob)	
Part Number	Weight (g)	Part Number	Weight (g)	Part Number	Weight (g)
QCSQ1212-OG	130	QCSQ1212-BK	130	QCSQ1212-S	145
QCSQ1616-OG	150	QCSQ1616-BK	150	QCSQ1616-S	165
QCSQ2509-OG	220	QCSQ2509-BK	220	QCSQ2509-S	245
QCSQ2512-OG	240	QCSQ2512-BK	240	QCSQ2512-S	265
QCSQ3212-OG	220	QCSQ3212-BK	220	QCSQ3212-S	245
QCSQ3216-OG	240	QCSQ3216-BK	240	QCSQ3216-S	265

QCSQ-L SLIDING LOCKS FOR SQUARE BAR WITH HANDLE



Body	Handle	Shafts / Wedge	Flat Spring
Die-cast zinc Chrome plated	SCS13 stainless steel (Equivalent to SUS304)	Stainless steel	C519P phosphor bronze

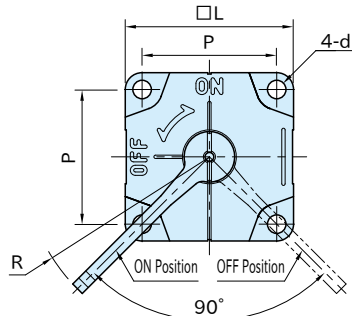

★ **Key Point** — The handle is accessible from the side even in tight spaces.

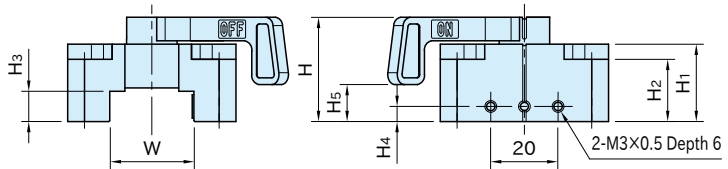

Part Number	L	H	W (+0.05/0)	H3 (+0.2/0)	H1	H2	H4	R	H5	P	d	Weight (g)
QCSQ1212-L	40	29	12	12	22	18.5	6	46	11	32	4.5	150
QCSQ1616-L		33							16			26
QCSQ2509-L	50	31	25	9	23	18.5	4.5	55.5	11	40	5.5	250
QCSQ2512-L		34							12			26
QCSQ3212-L		32	38	16	30	25.5	8		18			250
QCSQ3216-L									18			270

Continuing on Next Page

How To Use

Operating Instructions

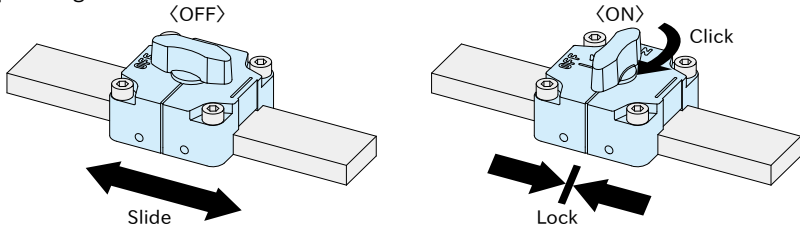

The slide is locked when the knob is at "ON" position.

Usage Instructions * Refer to the "Note" for safety use.

- Slide the steel bar.

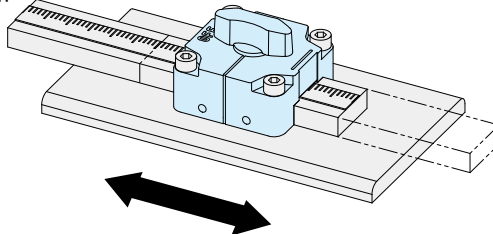

- Slide the Sliding Locks For Square Bar.

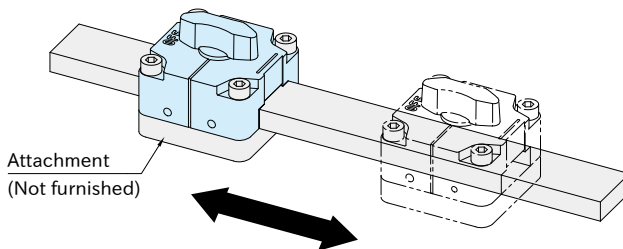

Steel Bar Materials

Usable Materials: Flat bar (JIS h14 grade) made of SS400, S45C or SUS304 etc.



	Size	W	H
QCSQ	1212	12 ($_{-0.43}^0$)	12 ($_{-0.43}^0$)
	1616	16 ($_{-0.43}^0$)	16 ($_{-0.43}^0$)
	2509	25 ($_{-0.52}^0$)	9 ($_{-0.36}^0$)
	2512		12 ($_{-0.43}^0$)
	3212	32 ($_{-0.62}^0$)	
	3216		16 ($_{-0.43}^0$)

Performance Curve

■ The displacement of steel bar by axial load (Static load from single direction)

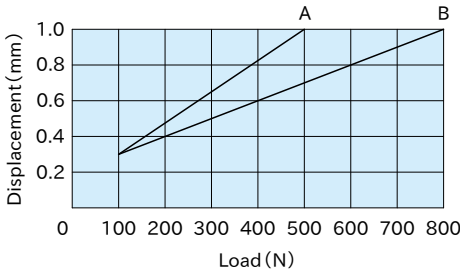

A: QCSQ 1212,1616
 B: QCSQ 2509,2512
 QCSQ 3212,3216

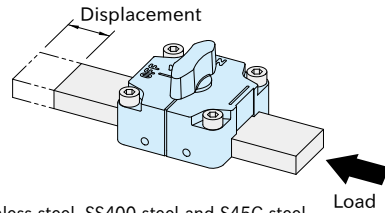

Note: The above data is for a flat bar made of SUS304 stainless steel, SS400 steel and S45C steel. Using an aluminum flat bar, the surface will be scratched or dent by applied load.

Technical Information

- Heat resistance : Up to 90°C
- Rated load : QCSQ 1212,1616 : 500N
 QCSQ 2509,2512,3212,3216 : Up to 800N

Note

The following conditions may cause displacement increasing or misalignment.

1. Use under slippage or chattering caused by vertical or horizontal loads

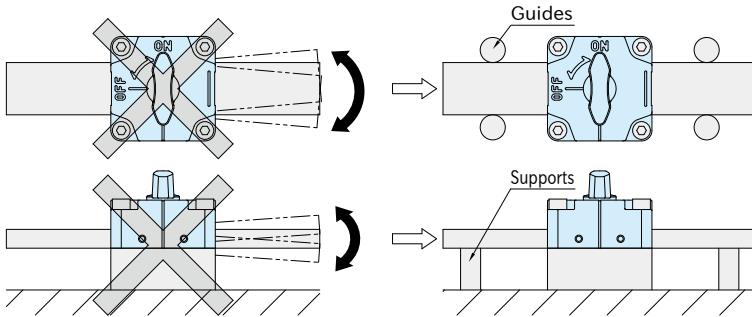

2. Use with a clearance between the steel bar and the base when the Sliding Locks at "ON" position.

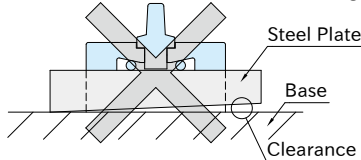

3. Use under excess shock or vibration

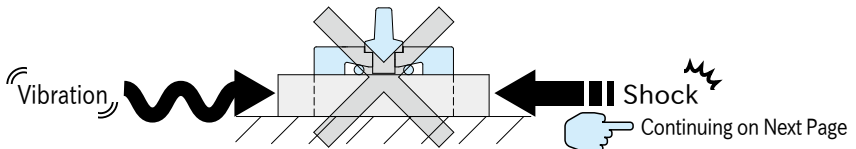

QCSQSP

RISER PLATES FOR SLIDING LOCK

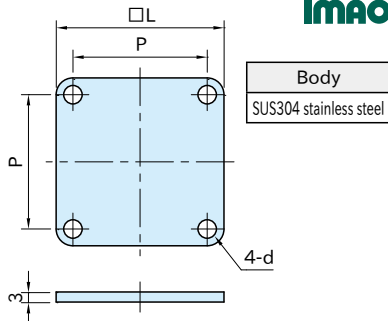

Part Number	L	d	P	Weight (g)
QCSQSP4003	40	4.5	32	35
QCSQSP5003	50	5.5	40	55

How To Use

■ How to Use Riser Plate

Riser Plates (to be ordered separately) can lift the steel bar to create a clearance between the steel bar and the base.

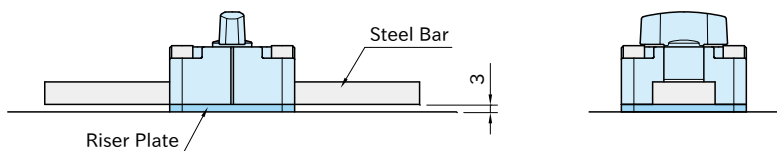

■ How to Use Tapped Holes on Side Surface

Can be used with attachments such as pointer plates and brackets.

Screw Size M3×0.5

Note: Screw depth must be 6mm or less.

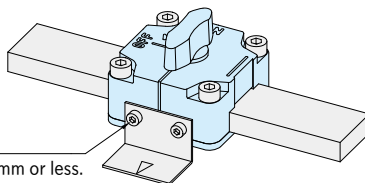

■ How to Use Scale Plate

Scale plate can be put on the steel bar.

Note: Fit scale plate inside the slot in the figure below.

Putting scale plate outside the slot cause interference between scale plate and Sliding Lock, and this may cause failure.

Scale plate can not be put on the [QCSQ1212](#) or [QCSQ1616](#).

ES1N Scale Plate is separately available.

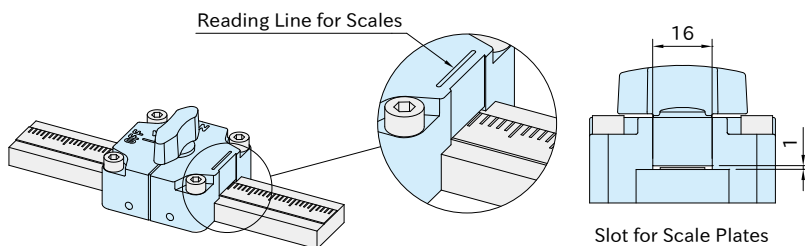



QCIC-F

ONE-TOUCH INDEXING CLAMPS



QCIC-F-2P

(ON Position)



QCIC-F-2P

(OFF Position)



QCIC-F-2P

(Without
Spring Pressure)

QCIC-F-3P

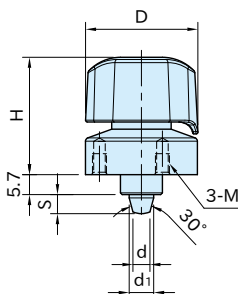
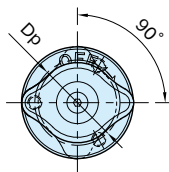
(With
Spring Pressure)

(ON Position)

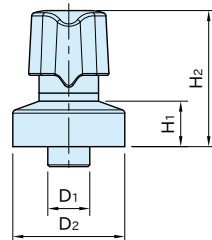

(OFF Position)

Body	Tapered Pin	Indicator	Knob
SCM440 steel Electroless nickel plated	SCM435 steel Electroless nickel plated	A5056 aluminum alloy Anodized Red	Polyamide (glass-fiber reinforced) Black

★ Key Point

Locating and clamping at once
Easy to read ON/OFF position

Size	Proper Plate Thickness	D	D ₁ (-0.01 -0.03)	D ₂	H	H ₁	H ₂	d	d ₁	S	M	D _p	Proper Tapered Bushings
QCIC05F26	6~14	26	10	26	29	11	33	3.3	5	4.2	M3×0.5 Depth 5	20	QCIC05TB
QCIC07F32	6~15	32	12	32	34	13	39	4.9	7	5	M4×0.7 Depth 6	24	QCIC07TB

Part Number	Clamping Force (N)	Spring Pressure (N)	Weight (g)
QCIC05F26-2P	140	—	60
QCIC07F32-2P	170	—	105
QCIC07F32-3P		9	110

QCIC-TB TAPERED BUSHINGS



Supplied With

- QCIC05F26: 3 of socket-head cap screws(Stainless Steel), M3×0.5-6L
- QCIC07F32: 3 of socket-low-head cap screws(Stainless Steel), M4×0.7-8L

Feature

- Clamping by the tapered pin allows locating and fixing with no clearance at once.
- Use with the dedicated tapered bushing.
- ON/MID/OFF mark on the body and the knob position allow to visually recognize clamping or unclamping.
- The red indicator appears to show the unclamping state when the knob is in OFF position.

Without Spring Pressure

2 positions of ON/OFF

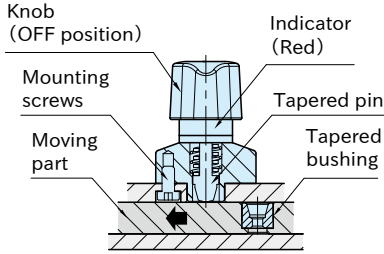

Knob is in OFF position.

The tapered pin remains inside when releasing the knob.

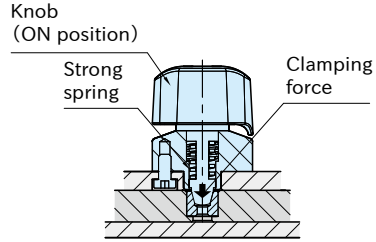

Knob is in ON position.

- Turn the knob to "ON" when the tapered pin and tapered bushing are aligned.
- Clamping force is generated by compressing strong spring and the tapered pin clamps the tapered bushing. The knob clicks when it is clamped.

With Spring Pressure

- 3 positions of ON/MID/OFF
- The plate is movable while receiving spring pressure of the coil spring inside the body.
- The tapered pin and tapered bushing automatically engage by spring pressure when they are aligned. (The knob positions in "MID".)

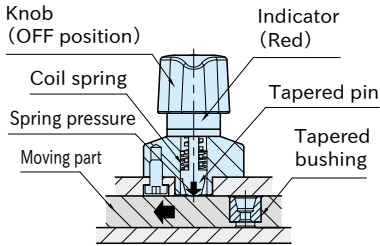

Knob is in OFF position.

- The tapered pin keeps pushed-out-state when releasing the knob. (The knob turns to "MID".)
- In MID position, the tapered pin does not retract into the body when colliding with the step and it can not pass through.

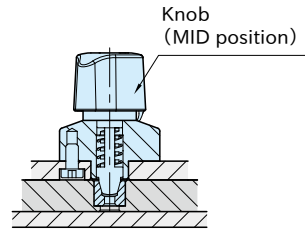
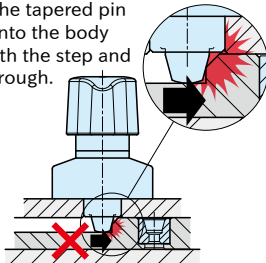

Knob is in MID position.

- The tapered pin and tapered bushing engage by spring pressure when they are aligned.
- The knob moves to "MID".
- Turn the knob from "MID" to "ON".
- Clamping force is generated by compressing strong spring and the tapered pin clamps the tapered bushing. The knob clicks when it is clamped.

Continuing on Next Page

Technical Information

Size	Heatresistant Temperature (°C)	Allowable Load (N)
QCIC05F26	80	900
QCIC07F32		1300

Repeatability: ± 0.05

How To Use

■ Without Spring Pressure

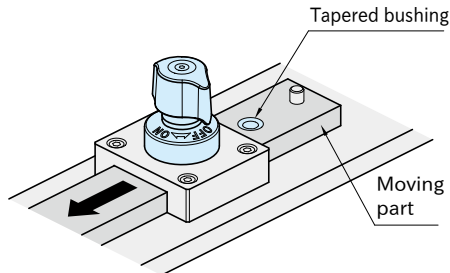

- ① Ensure that the knob is positioned at "OFF". Slide the moving part.

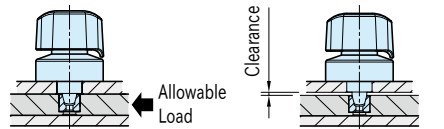

Recommended clearance between plates: 0.2 mm or less

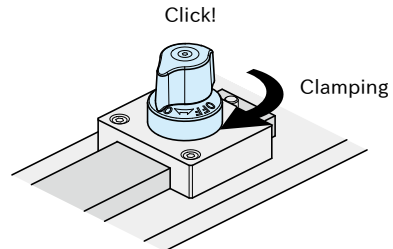

- ② Turn the knob to "ON" for clamping. The knob clicks when it is clamped.
Note: For **QCIC-F-2P** (Without spring pressure), do not unclamp when the tapered pin is receiving axial load. (The tapered pin could not return due to structure.)

■ With Spring Pressure

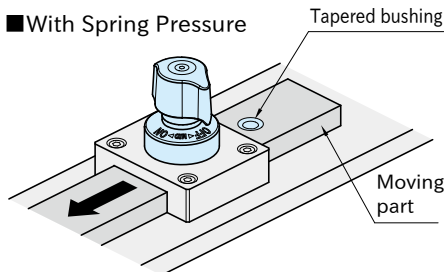

- ① Slide the moving part when the knob is positioned at "OFF".

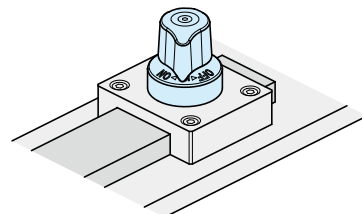

- ② The tapered pin and tapered bushing engage by spring pressure when they are aligned. The knob moves to "MID".

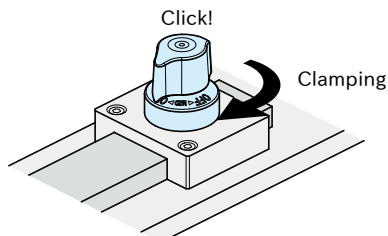

- ③ Turn the knob from "MID" to "ON" for clamping. The knob clicks when it is clamped.

Application Example

Locating and clamping for sliding plate

ONE-TOUCH INDEXING CLAMPS

QCIC-F-P

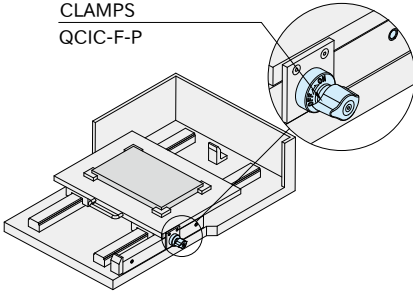

Locating and clamping for rotating unit

ONE-TOUCH INDEXING CLAMPS

QCIC-F-P

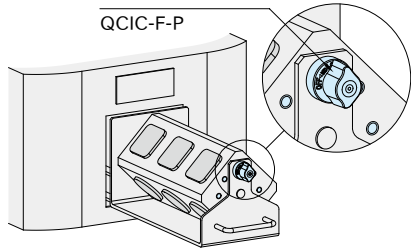

How To Install

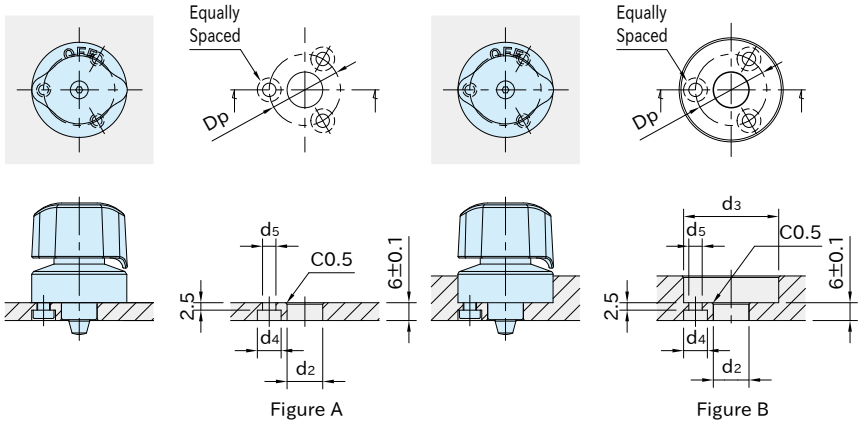

Size	Proper Plate Thickness	Figure	d ₂ (H7)	d ₃	d ₄	d ₅	Dp
QCIC05F26	6	A	10	—	6.5	3.4	20
	Over 6, 14 or less	B		27			
QCIC07F32	6	A	12	—	8	4.5	24
	Over 6, 15 or less	B		33			

Reference

"How To Install" of [QCIC-TB](#) Tapered Bushings.

QCIC-M

ONE-TOUCH INDEXING CLAMPS



QCIC-M-P
(ON position)



QCIC-M-P
(OFF position)



For **QCIC-M-2P**
(Sticker for
without spring
pressure type)



For **QCIC-M-3P**
(Sticker for
with spring
pressure type)

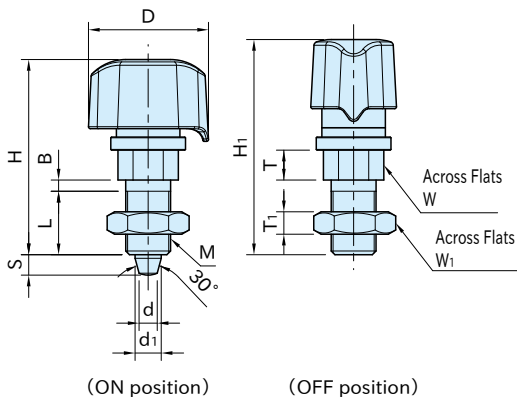
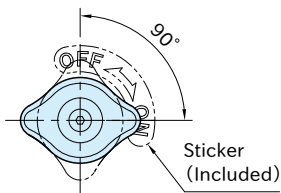

Body	Tapered Pin	Indicator	Knob
SCM440 steel Electroless nickel plated	SCM435 steel Electroless nickel plated	A5056 aluminum alloy Anodized Red	Polyamide (glass-fiber reinforced) Black

★Key Point

Locating and clamping at once

Size	Proper Plate Thickness	D	H	H ₁	d	d ₁	S	L	B	M	W	W ₁	T	T ₁	Proper Tapered Bushings
QCIC05M10	8~10	26	44	48	3.3	5	4.2	15	2	M10X1 (Fine Thread)	13	17	7	5	QCIC05TB
QCIC07M12	9~11	32	52	58	4.9	7	5	17	3	M12X1.5(Fine Thread)	14	19	8	6	QCIC07TB

Part Number	Clamping Force (N)	Spring Pressure (N)	Weight (g)
QCIC05M10-2P	140	—	45
QCIC07M12-2P	170	—	70
QCIC07M12-3P		9	70

QCIC-TB TAPERED BUSHINGS**Supplied With**

- **QCIC-M-2P** : ON/OFF sticker
- **QCIC-M-3P** : ON/MID/OFF sticker

Note: The attached sticker is an aluminum with thickness of 0.2 mm and has an adhesive on the back side.

Feature

- Clamping by the tapered pin allows locating and clamping with no clearance at once.
- Only a tapped hole is required for mounting.
- Not only can be used with a tapered bushing, but also with a through hole made on the plate.
- The red indicator appears to show the unclamping state when the knob is in OFF position.
- Use **QCIC-F** ONE-TOUCH INDEXING CLAMPS to set ON/OFF position at your desired place.

Without Spring Pressure

2 positions of ON/OFF

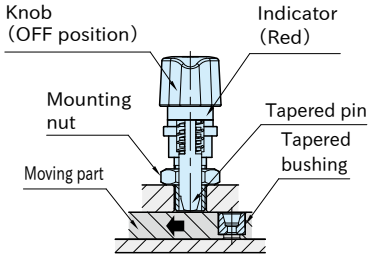

Knob is in OFF position.

The tapered pin remains inside when releasing the knob.

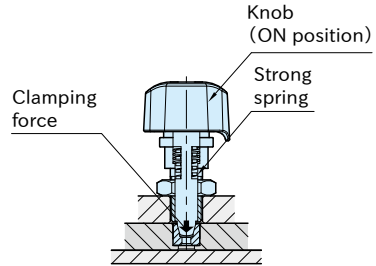

Knob is in ON position.

- Turn the knob to "ON" when the tapered pin and tapered bushing are aligned.
- Clamping force is generated by compressing strong spring and the tapered pin clamps the tapered bushing. The knob clicks when it is clamped.

With Spring Pressure

3 positions of ON/MID/OFF

- The plate is movable while receiving spring pressure of the coil spring inside the body.
- The tapered pin and tapered bushing automatically engage by spring pressure when they are aligned. (The knob positions in "MID".)

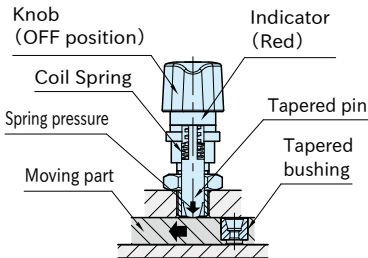

Knob is in OFF position.

- The tapered pin keeps pushed-out-state when releasing the knob. (The knob turns to "MID".)
- In MID position, the tapered pin does not retract into the body when colliding with the step and it can not pass through.

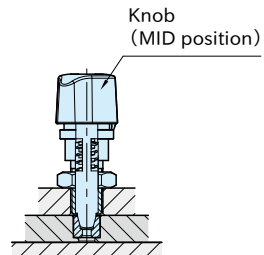
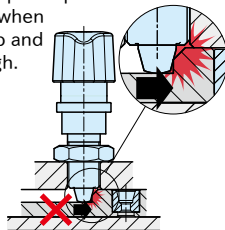

Knob is in MID position.

- The tapered pin and tapered bushing engage by spring pressure when they are aligned.
- The knob moves to "MID".
- Turn the knob from "MID" to "ON".
- Clamping force is generated by compressing strong spring and the tapered pin clamps the tapered bushing. The knob clicks when it is clamped.

Continuing on Next Page

Technical Information

Size	Heatresistant Temperature (°C)	Allowable Load (N)
QCIC05M10	80	900
QCIC07M12		1300

Repeatability: ± 0.05

How To Use

■ Without Spring Pressure

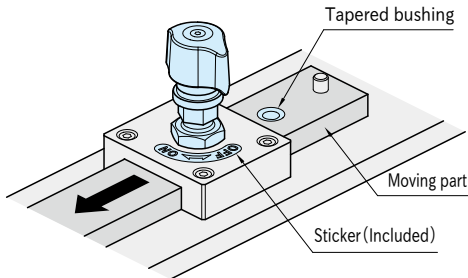

- ① Ensure that the knob is positioned at "OFF". Slide the moving part.

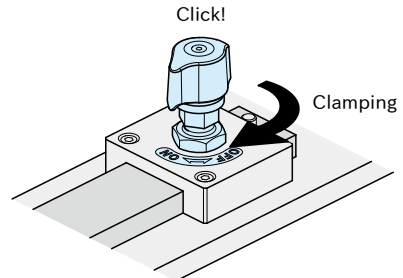
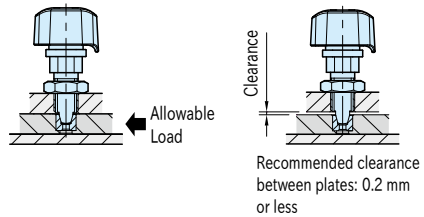

- ② Turn the knob to "ON" for clamping. The knob clicks when it is clamped.
Note: For [QCIC-M-2P](#) (Without Spring pressure), do not unclamp when the tapered pin is receiving axial load. (The tapered pin could not return due to structure.)

■ With Spring Pressure

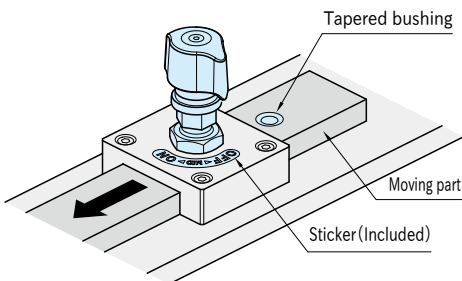

- ① Slide the moving part when the knob is positioned at "OFF"

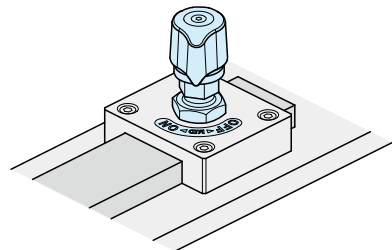

- ② The tapered pin and tapered bushing engage by spring force when they are aligned. The knob moves to "MID".

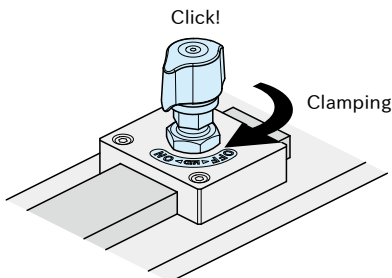

- ③ Turn the knob from "MID" to "ON" for clamping. The knob clicks when it is clamped.

Application Example

Locating and clamping for suction arms

ONE-TOUCH INDEXING CLAMPS
QCIC-M-P

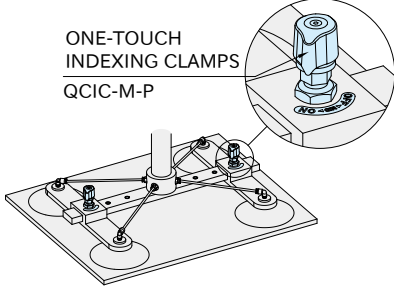

Locating and clamping for rotating pallet

ONE-TOUCH INDEXING CLAMPS
QCIC-M-P

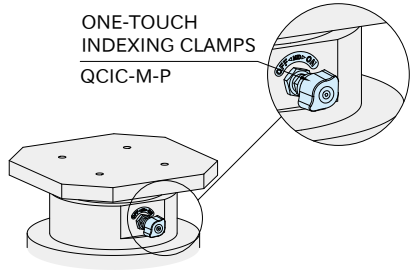

How To Install

Mounting Hole Dimensions

Note: Without tapered bushing

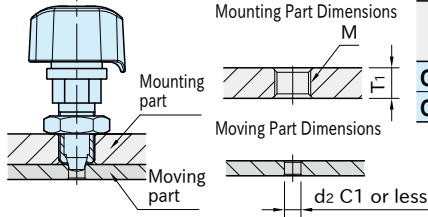

Size	d ₂	T ₁ (Proper Plate Thickness)	M
QCIC05M10	3.7~4.6	8~10	M10×1 (Fine Thread)
QCIC07M12	5.3~6.6	9~11	M12×1.5 (Fine Thread)

Installation Instructions

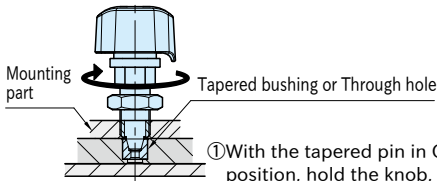

① With the tapered pin in ON position, hold the knob, and turn the body and screw it until the tapered pin touches lightly to the tapered bushing.

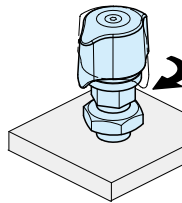

② Hold the knob and screw it about 90 degrees further.

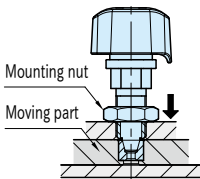

③ Fix the mounting nut. Turn the knob to OFF position and make sure the moving part slides smoothly and the knob clicks.

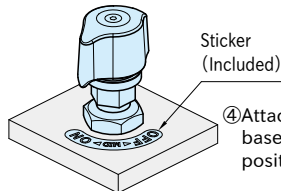

④ Attach the sticker based on ON or OFF position.

Reference

"How To Install" of [QCIC-TB](#) Tapered Bushings

QCIC-TB

TAPERED BUSHINGS

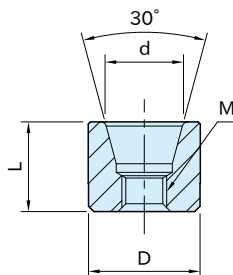

Body

S45C steel
Electroless nickel
plated

★Key Point

Bushing for ONE-TOUCH INDEXING CLAMPS

Part Number	d	D ($+0.01$ -0.005)	L (± 0.1)	M	Weight (g)
QCIC05TB	5	8	6	M3×0.5	2
QCIC07TB	7	10	8	M4×0.7	5

Application Example

■How To Install

Press fit on the plate.

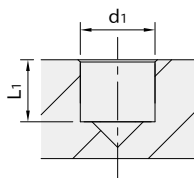

Part Number	d ₁ (H7)	L ₁ (± 0.1)
QCIC05TB	8	6.2
QCIC07TB	10	8.2

Note: Fix these bushings with adhesive if they can come off.

Reference

- **QCIC-F** One-touch indexing clamps
- **QCIC-M** One-touch indexing clamps

■How To Remove

For removal, insert screws into the tapped hole and screw it.

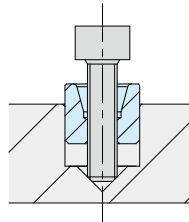



LSM

LINEAR-MOTION STOPPERS

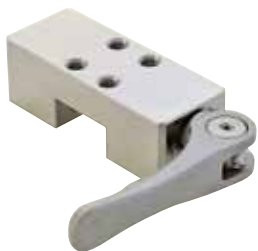

Body	Handle	Ring Nut / Spacer	Push Bar
S45C steel Electroless nickel plated	SCM440 steel Quenched and tempered Electroless nickel plated	SCM435 steel Quenched and tempered Electroless nickel plated	S45C steel

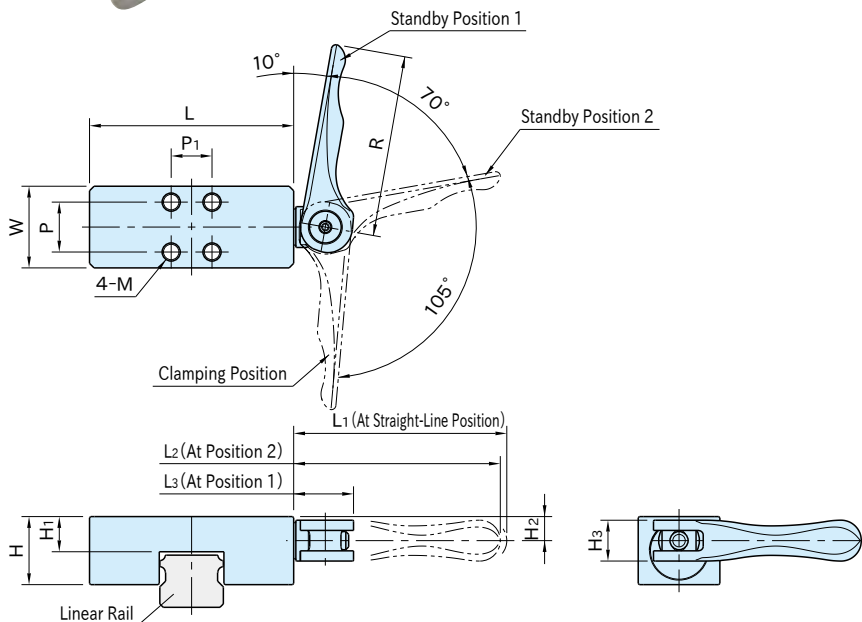

Part Number	Linear Size	L	W	H	H ₁	R	H ₃	H ₂	L ₁	L ₂	L ₃	M
LSM-20	20	63	26	22	11.5	63	14	7.8	76	73	23	M5×0.8 Depth 10
LSM-25	25	70	30	24	13.5			9.5				M6×1 Depth 12
LSM-30	30	90	36	30	15.5	80	18	10.6	95	92	27	M8×1.25 Depth 14
LSM-35	35	100	38	34	18.5			13.4				

Part Number	P	P ₁	Handle Operating Load (N)	Holding Force (N)	Weight (g)
LSM-20	16	13	40	150	283
LSM-25	18	15			376
LSM-30	22	18	50	250	729
LSM-35	24	24			932

How To Use

Turning the handle to the clamping position allows clamping the linear rail.

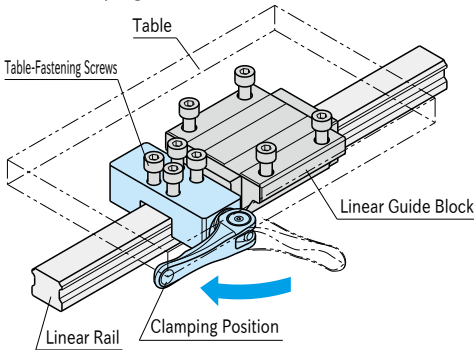

Note

- Unless the handle is turned to the clamping position, the engineered full clamping force can not be distributed.
- When the friction factor is extremely small due to oil or the like applied on the linear rail, the holding force can decrease.
- When a heavy impact load is applied, slippage can occur due to impact strength.

Feature

- Locks positively through simple operation.
- Always provides constant clamping force due to clamping with built-in spring.
- Can be operated in tight areas as shown below, due to no need of space for handle swivel.
- The handle can be changed in orientation every 90°.

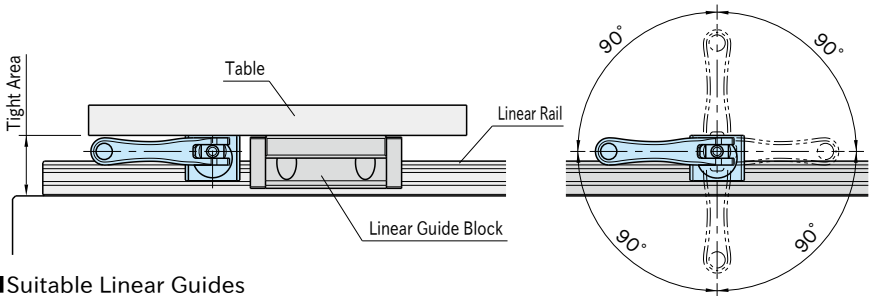

Suitable Linear Guides

Manufacturer	Type	
THK	SHS	SHS-C / SHS-LC, SHS-V / SHS-LV
	SSR	SSR-XW / SSR-XWM, SSR-XV / SSR-XVM, SSR-XTB
	HSR	HSR-A / HSR-AM / HSR-LA / HSR-LAM, HSR-B / HSR-BM / HSR-LB / HSR-LBM, HSR-CA / HSR-CAM / HSR-HA / HSR-HAM, HSR-CB / HSR-CBM / HSR-HB / HSR-HBM
	SR	SR-W / SR-WM / SR-V / SR-VM, SR-TB / SR-TBM / SR-SB / SR-SBM
IKO	LWE	LWEC / LWE / LWEG / LWEC...SL / LWE...SL / LWEG...SL, LWE...Q
	LWET	LWETC / LWET / LWETG / LWETC...SL / LWET...SL / LWETG...SL, LWET...Q
	LWES	LWESC / LWES / LWESG / LWESC...SL / LWES...SL / LWESG...SL, LWES...Q
	LWH	LWH...B / LWHG / LWH...SL / LWH...M
	LWHT	LWHT...B / LWHTG / LWHT...SL / LWHT...M
	LWHS	LWHS...B / LWHSG / LWHS...SL / LWHS...M

*) For use on other linear guides than above, contact us.

*) Note that Linear-Motion Stoppers are not products by manufacturers of linear guides, and any of such manufacturers are not liable or compensate for any trouble that may be caused by use of our Linear-Motion Stoppers.

PSLC-L

PNEUMATIC SHAFT-LOCKING CLAMPS



(Single Acting)

★Key Point

For automation of shaft locking

Body	Cover	Clamping Shaft
A5052 aluminum Anodized Natural	SUS304 stainless steel	A5052 aluminum Anodized

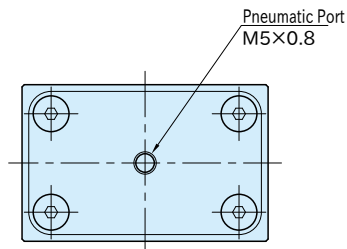
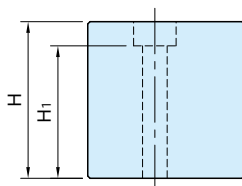
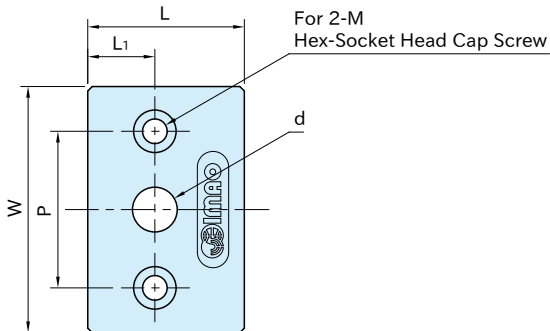

Part Number	d	L ₁	L	W	H	M	H ₁	P	Weight (g)	Suitable shaft dia. (h11)
PSLC10-5L	10	14	35	55	35	M5	29.5	35	220	φ 10
PSLC12-5L	12								210	φ 12
PSLC16-5L	16	15	40	63	40	M6	33.5	45	300	φ 16
PSLC20-5L	20								290	φ 20

Feature

- Spring clamping and pneumatic unclamping mechanism prevents the decrease of clamping force by air leakage.
- Available for remote and multiple operations.
- Perfect for use in limited space.
- Can be easily mounted with screws.

Note

- Clamping/unclamping operation should be done when the shaft stops. Can not be used as a brake of moving shaft.
- Do not force to move the clamped shaft.
- Do not operate frequently without shaft.
- Manual unclamping is not possible.

Application Example

- Three-way valve is recommended.
- This product can not be used as a bearing or a guide for shaft.

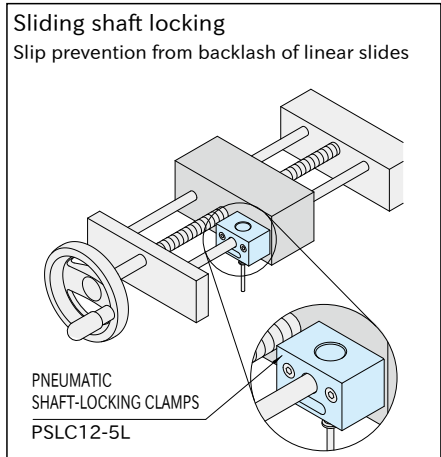
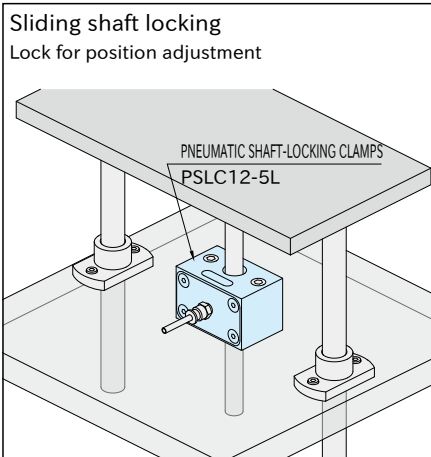

Technical Information

Part Number	Operating Air Pressure (MPa)	Holding Torque (N·m)	Sliding Load (N)
PSLC10-5L	0.5~0.7	0.5	100
PSLC12-5L		0.6	
PSLC16-5L		1.2	140
PSLC20-5L		1.5	

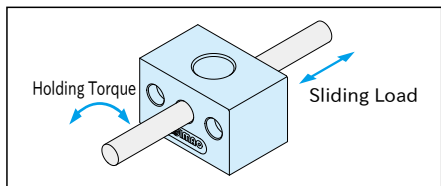

PSLC-M

PNEUMATIC SHAFT-LOCKING CLAMPS



(Single Acting)

★Key Point

For automation of shaft locking

Body	Cover	Clamping Shaft
A5052 aluminum Anodized Natural	A5052 aluminum Anodized	S45C steel Electroless nickel plated

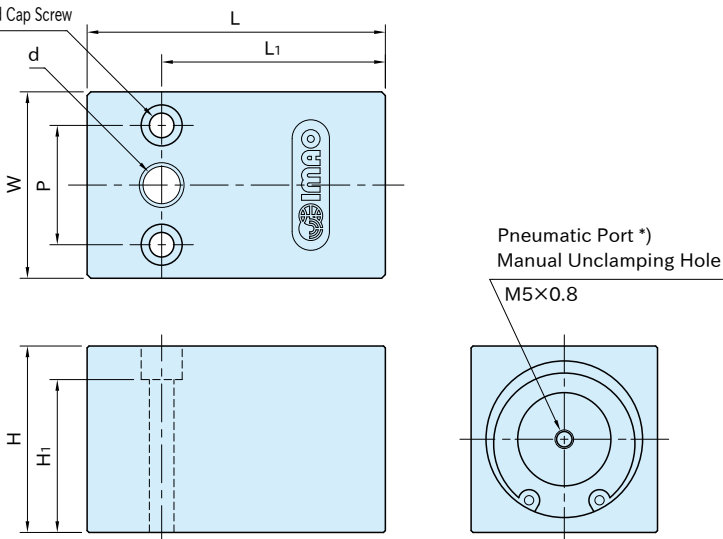
For 2-M
Hex-Socket Head Cap Screw*) A setscrew is attached when shipping.
For details, please refer to the features.

Part Number	d	L ₁	L	W	H	M	H ₁	P	Weight (g)	Suitable shaft dia. (h7,g6,f8) **)
PSLC10-3M	10	60	80	50	50	M 6	41	32	530	φ 10
PSLC12-3M	12								520	φ 12
PSLC16-3M	16	70	95	63	63	M 8	53	42	990	φ 16
PSLC20-3M	20								φ 20	
PSLC25-3M	25	95	130	80	80	M10	65	56	2310	φ 25
PSLC30-3M	30								φ 30	

**) Recommended shaft: Heat treated (over HRC50) or hard chrome plated (over HV750, over 10 μm thickness)

Supplied With

1 of hex socket setscrew

Feature

- Spring clamping and pneumatic unclamping mechanism prevents the decrease of clamping force by air leakage.
- Available for remote and multiple operations.
- Can be easily mounted with screws.
- Can be unclamped manually. The clamp can be released without air by tightening the setscrew fully into the manual unclamping hole.
- A setscrew is attached to pneumatic port when shipping. Remove the setscrew before air supply.

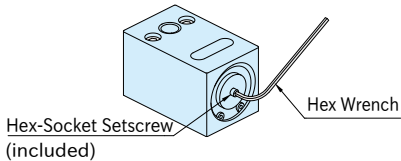

Note

- Clamping/unclamping operation should be done when the shaft stops. Can not be used as a brake of moving shaft.
- Do not force to move the clamped shaft.
- Do not operate frequently without shaft.

Application Example

- Three-way valve is recommended.
- This product can not be used as a bearing or a guide for shaft.

Sliding shaft locking

Vertical lock for elevator table

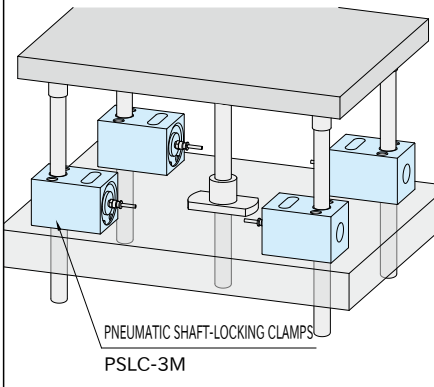

Technical Information

Part Number	Operating Air Pressure (MPa)	Holding Torque (N·m)	Sliding Load (N)
PSLC10-3M	0.3~0.7	6	800
PSLC12-3M		9	
PSLC16-3M		21	
PSLC20-3M		23	1600
PSLC25-3M		35	
PSLC30-3M		40	

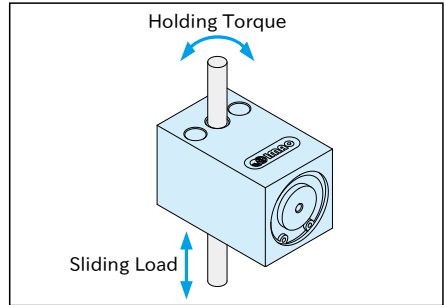

Sliding shaft locking

Horizontal lock with pneumatic cylinder

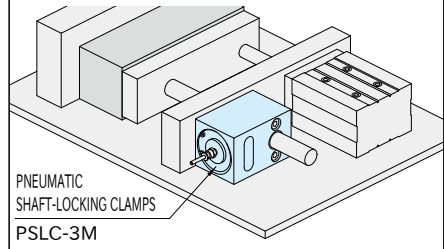

Spindle locking

Rotation lock for rotary stages

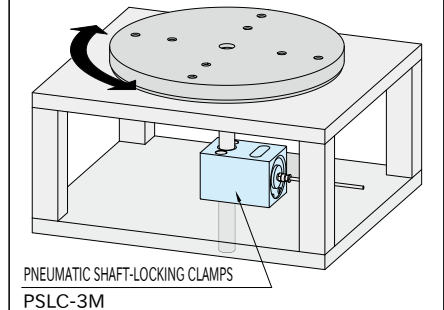

QCSPL

ONE-TOUCH SPINDLE LOCKS



QCSPL-OG

(Plastic knob, Orange)



QCSPL-BK

(Plastic knob, Black)



QCSPL-S

(Metal knob)

Type	Housing	Knob	Clamp Collar
QCSPL-OG	Polyamide (glass-fiber reinforced) Black	Polyamide (glass-fiber reinforced)	SUS630 stainless steel
QCSPL-BK			
QCSPL-S		SCS13 stainless steel (Equivalent to SUS304)	

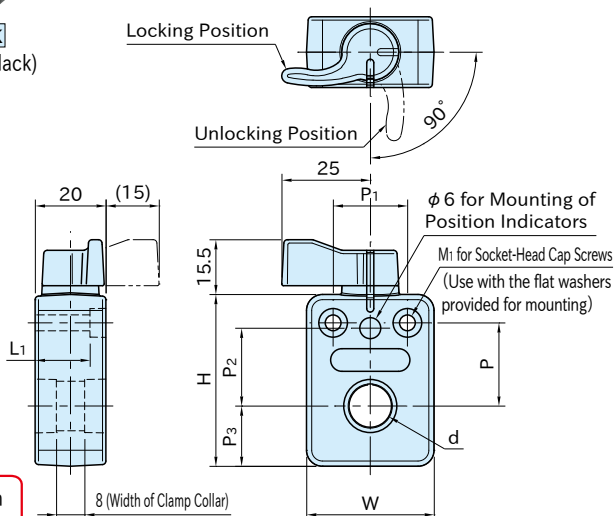

★ Key Point

Secure locking of spindles with one-touch action!

Plastic Knob			Metal Knob				d	W	H	M ₁	L ₁	P	P ₁	P ₂	P ₃	Suitable shaft dia.(h7) *)
Part Number		Weight (g)	Part Number	Weight (g)												
Orange	Black															
QCSPL0408-OG	QCSPL0408-BK	50	QCSPL0408-S	70	8	36	48.5	M4	14	23.5	21	22	17			φ 8
QCSPL0410-OG	QCSPL0410-BK		10		φ 10											
QCSPL0412-OG	QCSPL0412-BK		12		φ 12											
QCSPL0414-OG	QCSPL0414-BK		14		φ 14											
QCSPL0912-OG	QCSPL0912-BK		12		φ 12											
QCSPL0915-OG	QCSPL0915-BK	100	QCSPL0915-S	120	15	51	69	M5	12.5	17	34	30	26			φ 15
QCSPL0916-OG	QCSPL0916-BK		16		φ 16											
QCSPL0920-OG	QCSPL0920-BK		20		φ 20											

*) Using shafts with tolerances other than h7 may decrease the allowable holding torque or allowable sliding load

Supplied With

2 of Flat round washer(Stainless Steel)

Feature

- One-touch Spindle Locks enable quick and secure locking of shafts with one click of the knob.
- When One-touch Spindle Lock is operated, the knob clicks and the shaft is locked with a steady force. This provides reliable locking of shafts.
- The knob position and the indication line clearly indicate lock/unlock position.

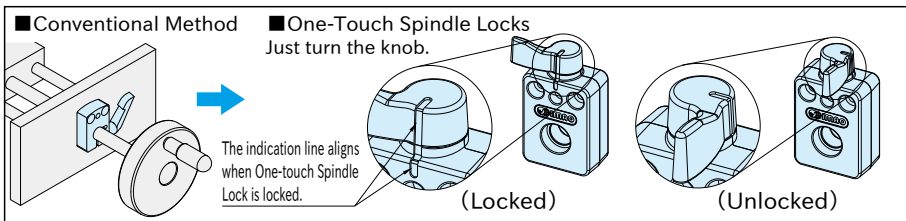

How To Use

For locking of spindle

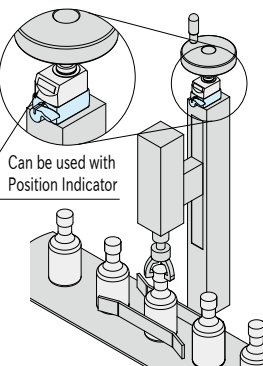
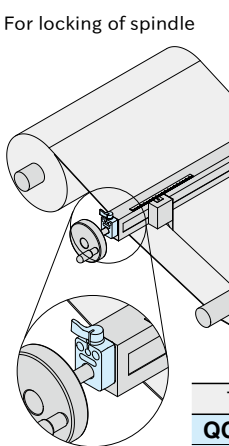

For locking of sliding shaft

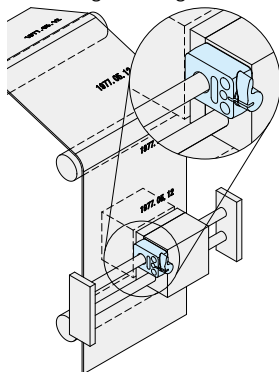

Types	Suitable position indicators
QCSPL04	SDP-04
QCSPL09	SDP-09-N

Note: To mount position indicators to One-touch Spindle Locks, use a rubber cushion supplied with position indicators.

Technical Information

One-touch Spindle Locks can fix both revolving and sliding of shafts.

Size	Allowable Holding Torque (N·m)	Allowable Sliding Load (N)
0408	3	400
QCSPL-0G	4	500
QCSPL-BK	5	500
QCSPL-S	0912	500
	0915	
	0916	
	0920	

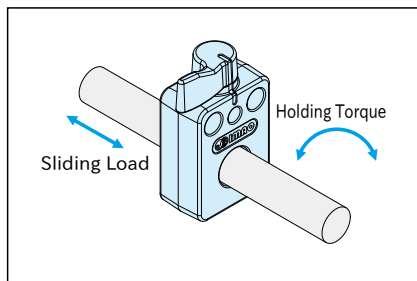

Note: The above information is for cold finished S45C steel bars with tolerance h7. Use this only as a guide.

Note

- Allowable tightening torque for mounting screws
 [QCSPL] 04 Size: 1.5 N·m, [QCSPL] 09 Size: 3.0 N·m
 Note: Tightening with torque greater than the allowable tightening torque may cause failure by deformation of the body.
- This product cannot be used as bearings or guides for shafts.
- Shafts may slip in environments where shocks or vibrations are present.

QSCA

QUICK SHAFT-LOCKING CLAMPS (Pneumatic)

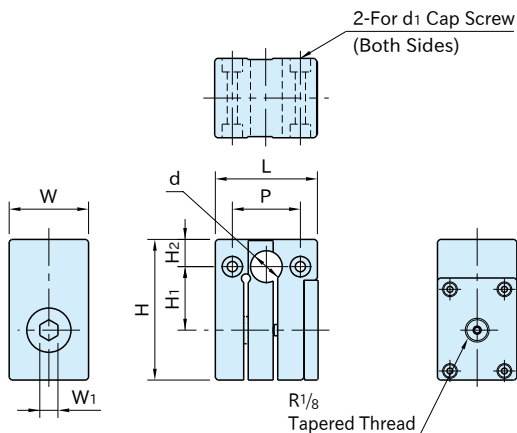

★ One Point

Clamping by spring pressure / Unclamping by air pressure

Body / Cover Plate	O-Ring
A5052 aluminum alloy Sand blasting finish Anodized Natural	Nitrile rubber

Part Number	d	H ₂	L	W	H	d ₁	P	W ₁	H ₁
QSCA10-N	10	12	45	35	62	M4 Counterbore depth 4.5	30	8	28
QSCA12-N	12								
QSCA14-N	14								
QSCA15-N	15	19	58	40	80	M5 Counterbore depth 5.5	35	10	35
QSCA16-N	16								
QSCA20-N	20								

Part Number	Holding Torque (N·m)	Sliding Load (N)	Weight (g)	Shaft Dia. (h6-h9)
QSCA10-N	1	150	230	φ 10
QSCA12-N	1.2			φ 12
QSCA14-N	1.4			φ 14
QSCA15-N	2.2	200	450	φ 15
QSCA16-N	2.4			φ 16
QSCA20-N	2.6			φ 20

How To Use

How to Install

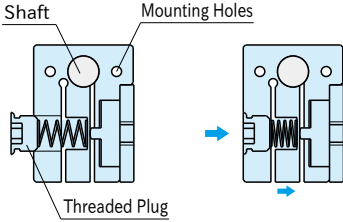

Slide the clamp over the shaft at the unclamped mode, and then fix the body using the 2 mounting holes.

Screwing the plug completely into the hole allows locking the shaft.

How to Operate

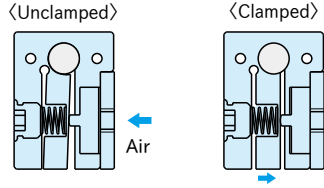

Supplying air allows compressing the spring to get the shaft unlocked.

Releasing the air allows getting the spring to work to lock the shaft.

Feature

- Air pressure to be applied : 0.5 - 0.7MPa Recommended to use with a three-way valve.
- The mechanism of spring-pressure clamping and air-pressure unclamping prevents shaft-locking force from getting lowered.
- Connecting air plumbing to multiple Quick Shaft-Locking Clamps installed allows doing clamping/unclamping in one operation.

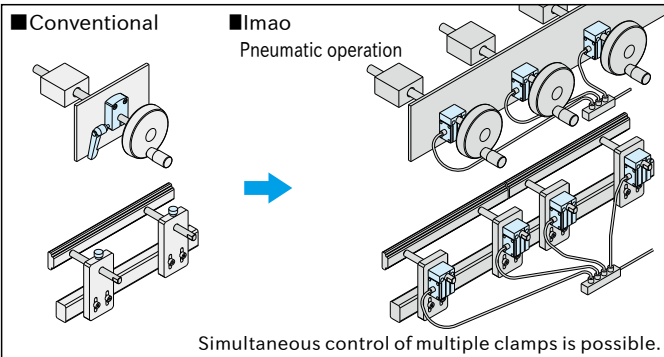

Plumbing Drawing

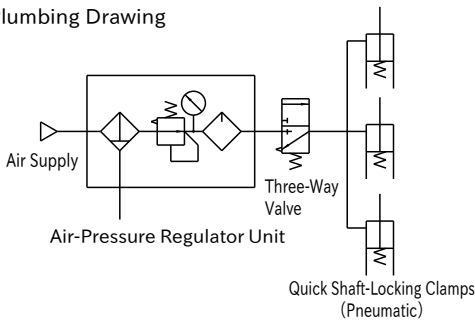

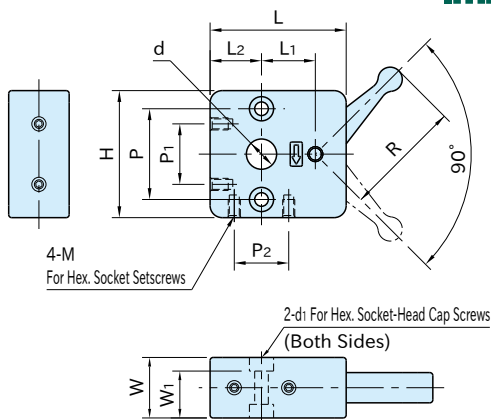
QSC**QUICK SHAFT-LOCKING CLAMPS****IMAO**

Body / Handle	Locking Block	Flat Spring
Die cast zinc Chrome plated finish	CAC402 cast bronze	SUS304 stainless steel

Part Number	d	L ₂	L	W	H	R	L ₁	d ₁	W ₁	P	M	P ₁	P ₂
QSC10S	10	17	45	20	42	39	17.6	M4	15.5	30	M4×0.7 Depth 6	20	18
QSC12S	12						18.8						
QSC14S	14						19.9						
QSC15L	15						24.1						
QSC16L	16	20	55	26	50	50	24.7	M5	20.5	35	M5×0.8 Depth 8	20	20
QSC20L	20						27						

Part Number	Weight (g)	Shaft Dia. (h9)
QSC10S	228	φ 10
QSC12S	224	φ 12
QSC14S	220	φ 14
QSC15L	428	φ 15
QSC16L	418	φ 16
QSC20L	359	φ 20

Supplied With

Four hex. socket setscrews

How To Use

- As the handle is turned down, it pushes the locking block toward the shaft for clamping. When the handle is released, the flat spring allows the locking block to be returned to the original position.
- Both faces can be used for installation. Two sides with two tapped holes can also be used for installation (remove the setscrews).

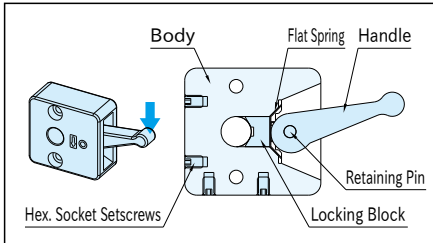

Note

Do not give hammer taps to the handle or extend the handle with a pipe or the like for easier clamping, to avoid any damage.

Greasing

Dimensions between the shaft-hole center and the sides are not precise. When installing a Quick Shaft-Locking Clamp using tapped holes provided on two sides, make position adjustments using a bracket, shim or the like to prevent conflicts between the shaft hole and a shaft. It is recommended that the cam section and the retaining pin be greased periodically (every about 30,000 cycles) for stable holding torque and sliding load.

Feature

- Designed to positively lock a lead screw or slide shaft with ease.
- Ideal especially in applications where position adjustments are often made, due to better workability than conventional holding methods using adjustable handles or knobs.
- Can also be used in limited space due to no need of space for handle's large swing.

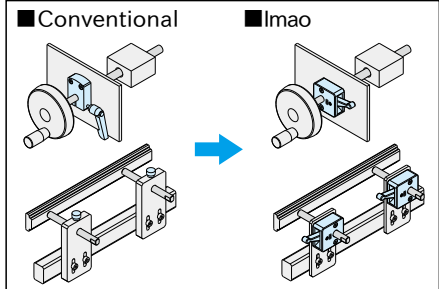

Technical Information

Part Number	Handle Operating Load (N)	Holding Torque (N·m)	Sliding Load (N)
QSC10S	80	2	220
QSC12S		3	
QSC14S		3.5	
QSC15L		4.5	
QSC16L		5.5	
QSC20L		6.5	

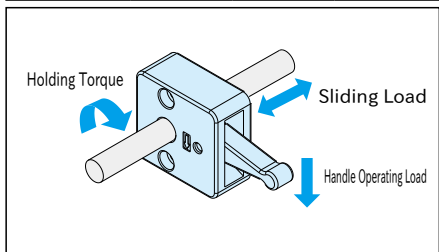

ONE-TOUCH
SLIDING LOCKS

ONE-TOUCH
INDEXING CLAMPS

LINEAR-MOTION
STOPPERS

PNEUMATIC SHAFT-
LOCKING CLAMPS

ONE-TOUCH
SPINDLE LOCKS

QUICK SHAFT-LOCKING
CLAMPS

ONE-TOUCH SLIDING LOCKS

